



S70 | Compact Loaders



Powerful things come in small packages



■ The size is small – the advantages aren't

In Bobcat's range of compact loaders, the S70 stands out because of its size – it's the smallest of the small! But it's the flexibility, convenience and overall usefulness of the S70 that make it really unique. With important advantages that make the machine safer, more durable and more comfortable, you can work on the most cramped and confined worksites, and under low ceilings.



■ A lasting impression

Your Bobcat S70 has been built to last, with some of the great advantages from our larger loaders:

- Reinforced lift arms
- Extra strong offset rims and wheel studs
- A new hydrostatic pump centering system replaces torsion springs with tension springs for reduced maintenance and increased uptime
- An automatic belt tensioner with robust components and a simple design.

■ Performing wonders

You'll enjoy the superior performance of the S70, with its 22.5 hp engine powering a fully hydrostatic, 4-wheel drive system. It can travel up to 10 km/h, but it's so easy to transport you can just load it on a trailer and go. Plus, the hydraulic flow and pump capacity make it a model of efficiency.



■ **Perfect comfort for a productive day's work**

The S70 offers you lots of comfort features, for a smoother ride, greater safety and less machine wear:

- The new pump mount casting and engine mount isolators reduce the vibration levels
- Excellent side and front visibility from the cabin
- Custom-developed headlights light up the work area
- Easy-to-use instrument panel to stay informed at all times
- Optional cabin heating and heavy duty tyres that increase traction.



Easy transport and service

■ A mini-powerhouse

With its ultra-compact dimensions:

- 901 mm wide
- 1814 mm high
- 2553 mm long with a 36" standard bucket attached
- 1291 kg operating weight

the S70 can be easily transported on a trailer behind a medium-sized car.



■ Serviceability: fast and easy

All standard service points such as filters and air bleeding system are easily accessible thanks to the large tail gate and the transversely mounted engine.



Machine Rating

| | |
|---------------------------------|----------------------------|
| Rated operating capacity | 343 kg |
| Tipping load | 686 kg |
| Pump capacity | 37 l/min @ 100% efficiency |
| System relief at quick couplers | 207 bar |
| Max. travel speed | 9.8 km/h |

Engine

| | |
|----------------------------------|-------------------------|
| Make / Model | Kubota / D1005-E3B-BC-3 |
| Fuel / Cooling | Diesel / Liquid |
| Max power @ 3000 RPM (SAE J1349) | 16.8 kW |
| Torque at 2200 RPM (SAE J1349) | 62.8 Nm |
| Number of cylinders | 3 |
| Displacement | 1001 cm ³ |
| Fuel tank capacity | 24.6 l |

Weights

| | |
|------------------|---------|
| Operating weight | 1268 kg |
|------------------|---------|

Controls

| | |
|---------------------------------|---|
| Vehicle steering | Direction and speed controlled by two hand levers |
| Loader hydraulics tilt and lift | Separate foot pedals |
| Front auxiliary | Lateral movement of right-hand steering lever |

Drive System

| | |
|--------------|---|
| Transmission | Infinitely variable tandem hydrostatic piston pumps, driving two fully reversing hydrostatic motors |
|--------------|---|

Standard Features

| | |
|--|------------------------|
| Automatically activated glow plugs | Rear and top window |
| Bob-Tach™ frame | Seat belt |
| Bobcat Interlock Control System (BICS) | Seat bar |
| Engine / Hydraulic system shutdown | Spark arrester muffler |
| Front auxiliary hydraulics | CE certification |
| High-back cushion suspension seat | |
| Instrumentation | |
| Lift arm support | |
| 23 x 5.70-12, 4-ply, Narrow tyres | |
| Operating lights, front and rear | |
| Operator cab* | |
| Parking brake | |

* Roll Over Protective Structure (ROPS) – meets requirements of SAE-J1040 and ISO 3471

Options

| | |
|---------------------|---------------------------------------|
| Heated enclosed cab | 23 x 8.50-12, 6-ply, Heavy duty tyres |
|---------------------|---------------------------------------|

Dimensions

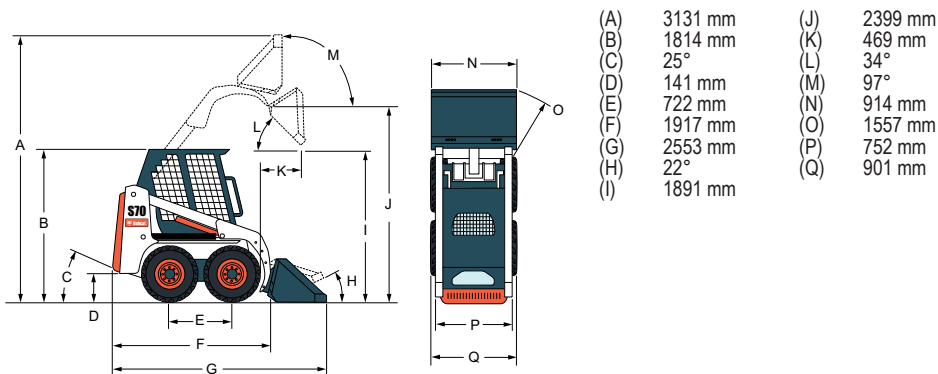

Attachments

- Angle broom*†
- Auger
- Backhoe
- Buckets
- Digger
- Dumping hopper
- Farm grapple
- Hydraulic breaker**
- Landplane
- Mini scraper
- Pallet fork
- Snow blower*
- Snow V-blade
- Soil conditioner
- Stump grinder
- Sweeper
- Tiller
- Trencher
- Utility blade
- Utility forks
- Utility grapple

*Attachment control kit required.

**When operating the loader with this attachment, a Special Applications Kit, which includes a 12 mm Lexan front door with 6 mm top and rear windows, must be used.

†Optional water kit.

Specifications and design are subject to change without notice. Pictures of Bobcat products may show other than standard equipment.

www.bobcat.eu



Bobcat®

